

مهتاب آب ایرانیان



MAHAB AB IRANIAN

Manufacturer of Industrial Valve

since 1993



2 years warranty

10 years service after sele

MAHAB AB IRANIAN

Product list:

Metalic seat gate valve	2
Rubber seat gate valve	4
Disk discharge valve.....	6
Butterfly valve (wafer type).....	8
<i>Cast Iron Double Flange Butterfly Valve</i>	10
Swing type check valve	12
Cast iron strainer	14
Pressure reduce valve	16
Safety valve	18
Hidro mechanic float valve	20
Knife gate valve	22
Air valve	24
Flap valve	26
Under ground fire hydrant	28

MAHAB AB IRANIAN

Cast Iron Metallic Seat Gate Valve

MAHAB AB - IR

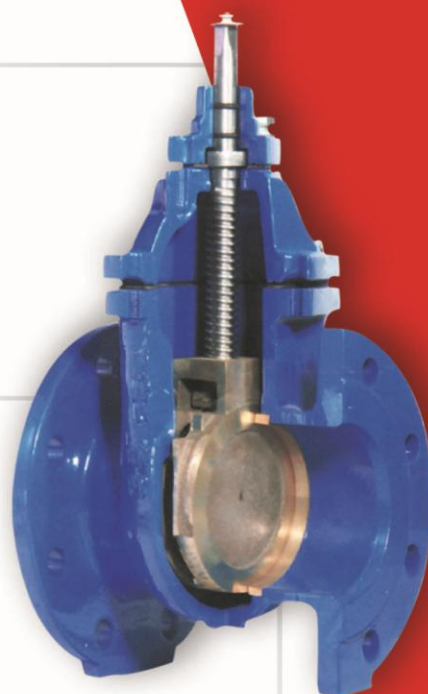

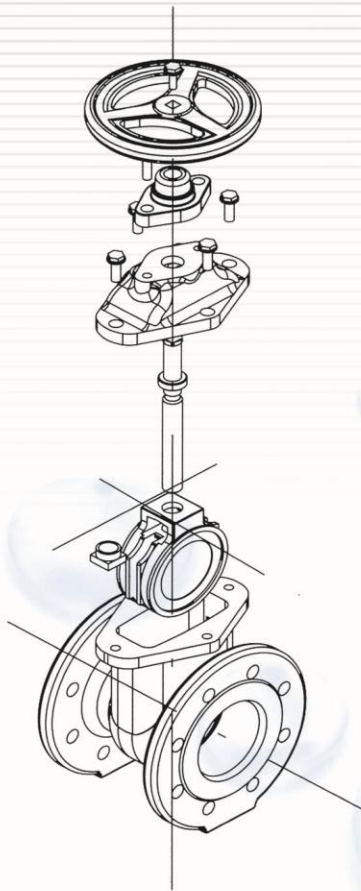

Cast Iron Metallic Seat Gate Valve

Technical Specification:

10bar Nominal Pressure (PN10)

50-350 mm Nominal Diameter (2"-14")

Gray cast iron (GG25) body&bonnet matterial

Cast bronze gate mattrial

Stainless Steel (X20Cr13) shaft matterial

Powder electro static epoxy coating

15bar body testing (according Iso5208)

11bar sealgate testing (according Iso5208)

Material and designing standard (DIN3352)

Flange mating dimension standard (DIN2501)DIN EN102-2

180° C working Temperature

Iran standard code :7736507925

The Material of Parts, According to DIN 3352

Part Name	Material Group	Material no	Code No	Material Standard
Body	Gray Cast Iron	0.6025	GG 25	DIN 1691 Or ISO 185
Gate	Copper Zinc Alloy			DIN 1705 Or ISO 426
Bonnet	Gray Cast Iron	0.6025	GG 25	DIN 1691 Or ISO 185
Stuffing box	Gray Cast Iron	0.6025	GG 25	DIN 1691 Or ISO 185
stem	Stainless Steel	1.4021	X20 Cr13	DIN 17440
Bonnet Gasket				DIN 3754
stem Nut	Stainless Steel	1.4021	X20 Cr13	DIN 17440
Bolts			Ck 15	DIN 933
Stuffing box Gasket				DIN 3754
Hand wheel	Gray Cast Iron	0.6025	GG 25	DIN 1691 Or ISO 185
Hand wheel Bolt & Washer			Ck 15	DIN 933
Body Seat Rings	For 90 deg Water copper zinc alloy			DIN 1705 Or ISO 426
Gland	Gray Cast Iron			DIN 1691 Or ISO 185
Packing	Flexible Graphite	0.6025	GG 25	

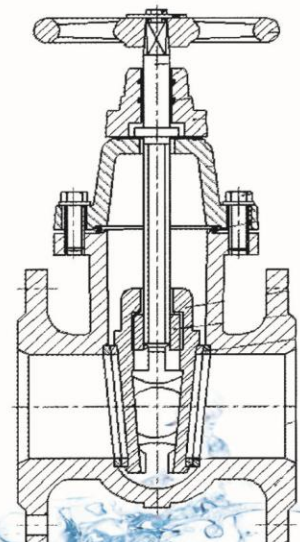

MAHAB AB IRANIAN

Cast Iron Rubber Seat Gate Valve

MAHAB AB - IR

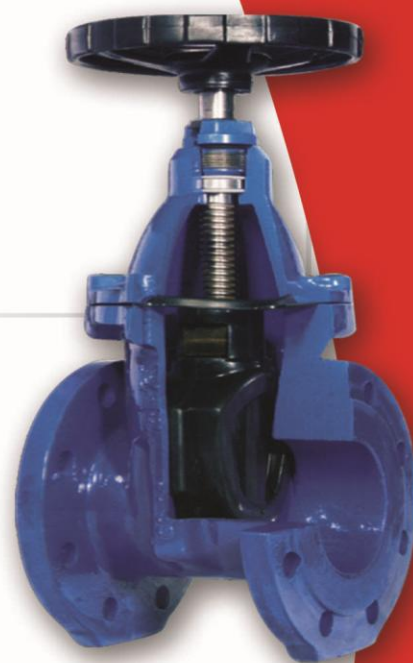

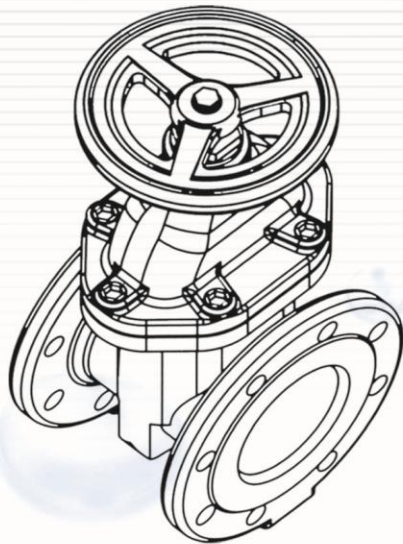

Cast Iron Rubber Seat Gate Valve

Technical Specification

50-250 mm Nominal Diameter (2"-10")

10&16bar Nominal Pressure (PN10&PN16)

Gray cast iron (GG25) body&bonnet matterial (for PN10)

Ductile iron (GGG40) body&bonnet material (for PN16)

Ductile iron gate material

NBR or EPDM rubber gatecover material

Stainless Steel (X20Cr13) shaft material

Powder electro static epoxy coating

Pressur test according to ISO 5208

Material and designing standard (DIN3351)

Flange mating dimension standard (DIN2501) DIN EN1092-2

Suitable for water, wastewater, oil and air

80° C working Temperature

Iran standard code : 7736507925

The Material of Parts, According to DIN 3352

PART NAME	MATERIAL
BODY & BONNET	GG25 For PN10 GGG40 For PN16 & 25
WEDGE	GGG40
HAND WHEEL	PLASTIC For PN 10 & 16 GG25 For PN 25
WEDGECOATING	EPDM / NBR
BODY BONNET GASKET	EPDM / NBR
HAND WHEEL BOLT & WASHER	XSCrNi18/10
GLAND	POM
GASKETO - RING	EPDM / NBR
DUST GUARD	EPM / NBR
WEDGE LOCK NUT	COPPERALLOY
BODY BONNET BOLT	STEEL 8.8 JS - 500
GASKET	EPDM / NBR
STEM	X20Cr13a

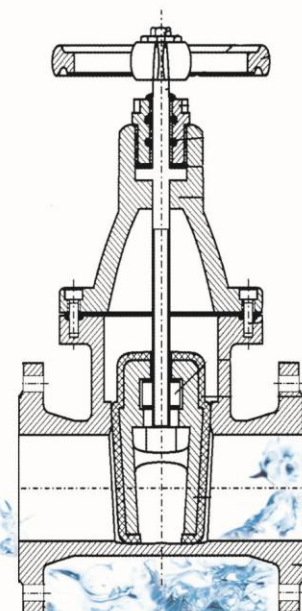

MAHAB AB IRANIAN

MAHAB AB - IR

Disk Discharge valve

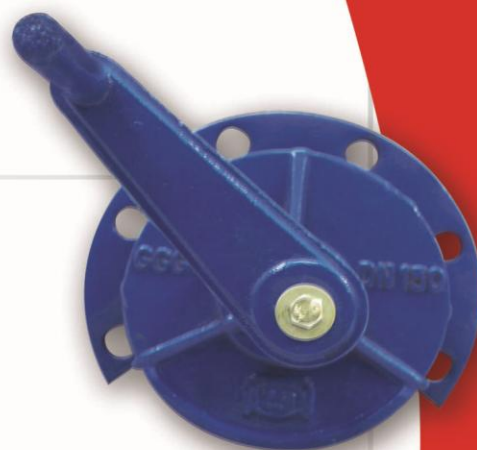

Disk Discharge valve

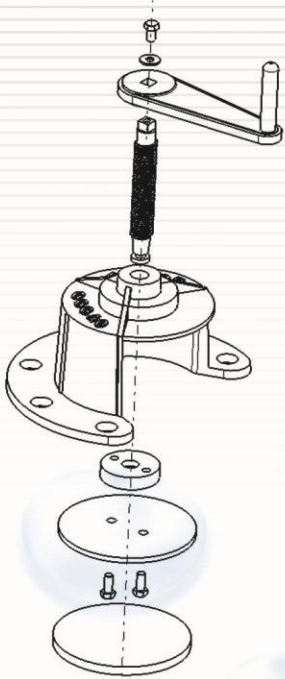

Technical Specification:

6bar Nominal Pressure (PN6)

80-300 mm Nominal Diameter(3"-12")

Ductile iron body material(GGG40)

Stainless Steel(X20Cr13)shaft material

Powder electro static epoxy coating

Flange mating dimension standard DIN2501

Low price, easy instalation ,long life, low weight

The Material of Parts, According to DIN 3352

Part name	Material
Body	GGG 40
Disk	GGG 40
Stam	X 20 Cr 13
Hand hold	GG 25
Seat	Silent Foam
Bolts	A2

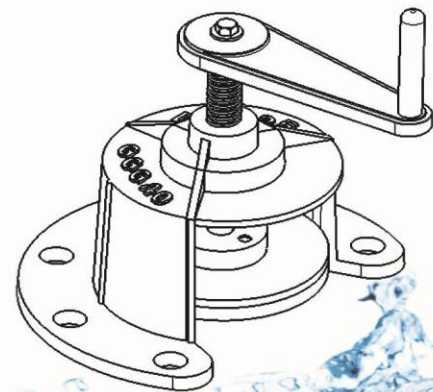

MAHAB AB IRANIAN

MAHAB AB - IR

Butterfly Valve (wafer type)

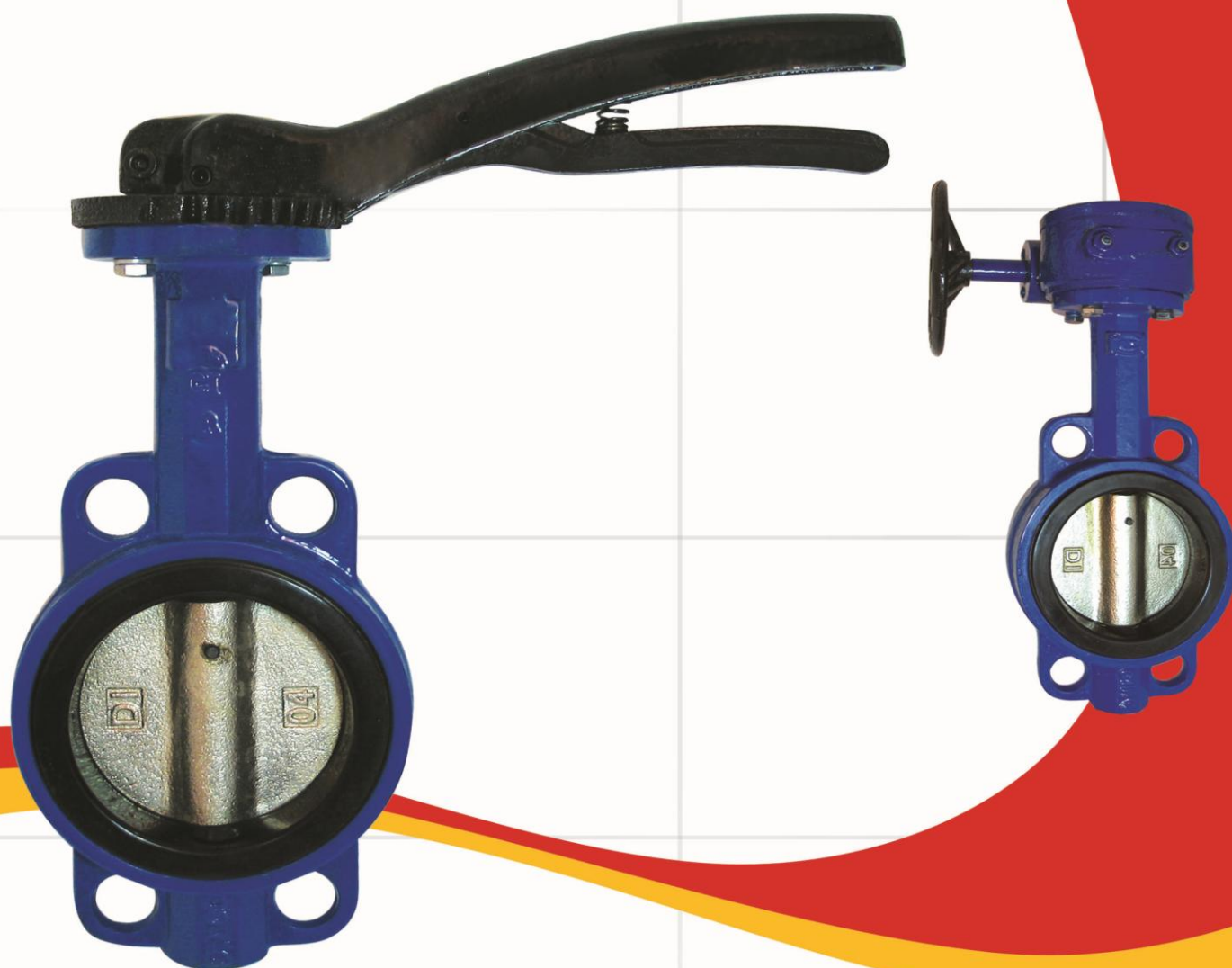

Butterfly Valve(wafer type)

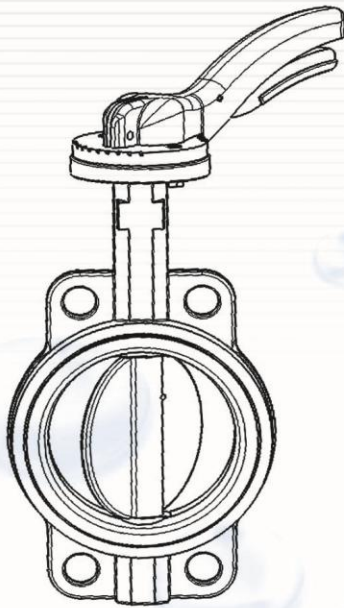

Technical Specification:

10bar&16bar Nominal Pressure(PN10 & PN16)

50-300 mm Nominal Diameter(2"-12")

Gray cast iron(GG25)body material

Ductile iron(GGG40)disk material for PN10

Stainless steel(1.4301)disk material for PN16

EPDM rubber for sealing

Powder electro static epoxy coating

Hand operation &gearbox operator&Pnumaticc actuator ability

Easy instalation and operation

80° C working Temperature

The Material of Parts, According to DIN 3352

Part name	Material
Body	GG25
Disk	GGG 40
Shaft	X20 Cr 13
Seat	NBR
Key	1.4571
Bolts	A2
Packing	EPDM
Handhold	GGG 40
Latch	GGG 40
Latch plate	GG 25

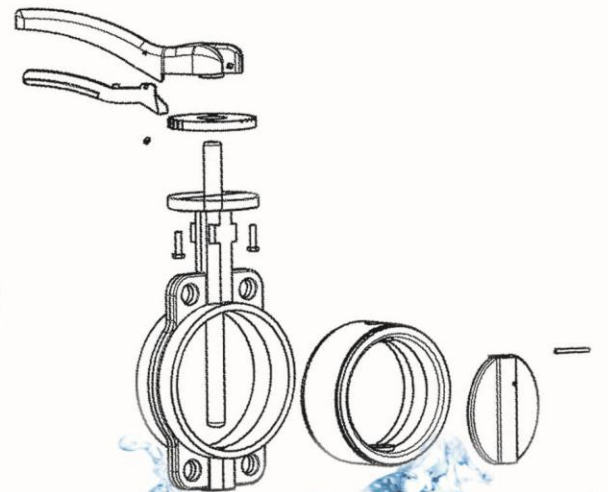

MAHAB AB IRANIAN

Cast Iron Double Flange Butterfly Valve

MAHAB AB - IR



Cast Iron Double Flanged Butterfly Valve

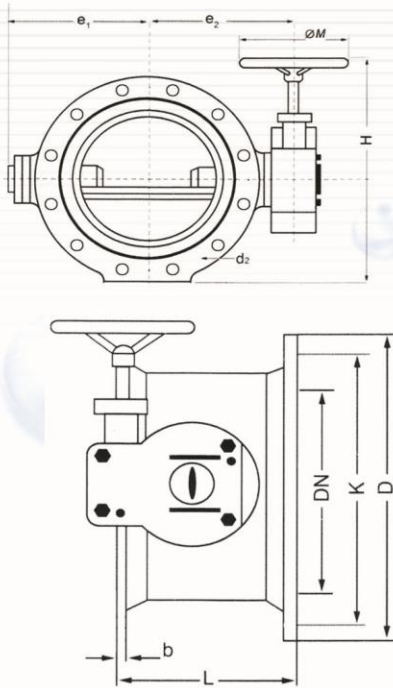

Technical Specification:

10bar&16bar Nominal Pressure(PN10 & PN16)

150-400 mm Nominal Diameter(6"-16")

Graycast iron(GG25)bodyfor PN10

Ductile iron (GGG40)body for PN16

Powder electro static epoxy coating

Ductile iron(GGG40)disk material

Space requirement standard(DIN3202)

Flange mating dimation standard (DIN9501)

Adjust bleand spareable NBR seat with gearbox equipment

Stainless Steel(X20Cr13)shaft material

The Material of Parts, According to DIN 3352

Part name	Material
Body	GGG40 (for PN 16) , GG 25 (for PN 10)
Disk	GGG 40
Cover	GG 25
Shaft	1.4021
Seating ring	NBR
Socket screw	A2
Bolts	A2
Oring	NBR
Key	1.4571
Gearbox	GG 25

MAHAB AB IRANIAN

MAHAB AB - IR

Cast Iron Swing Type Check Valve



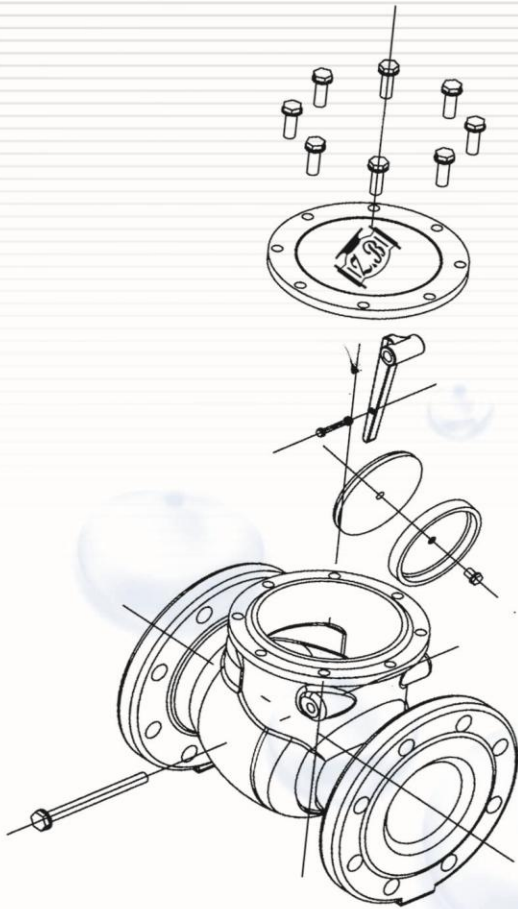

Cast Iron Swing Type Check Valve

Technical Specification

10bar&16bar Nominal Pressure(PN10 & PN16)

50-250 mm Nominal Diameter(2"-10")

Gray cast iron(GG25)body material in order ductile iron (GGG40)body material

Stainless Steel(X20Cr13) hing pine material

Powder electro static epoxy coating

Material and designing according to standard(ISO 9952)

Body and flap testing according to DIN

Flange mating dimation standard (DIN2501)

Space requirements standard DIN3202

90° C working Temperature

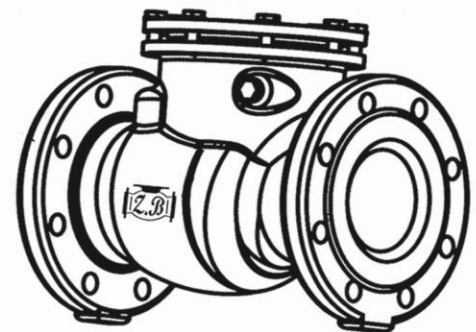

The Material of Parts, According to DIN 3352

Part Name	Material Group	Material no	Code No	Material Standard
Body	Gray Cast Iron	0.6025	GG 25	DIN 1691 Or ISO 185
Cover	Gray Cast Iron	0.6025	GG 25	DIN 1691 Or ISO 185
Arm	Ductil Cast Iron	0.705	GGG 50	DIN 1693
Arm hinge Pin	Stainless Steel	1.4021	X20 Cr13	DIN 17440
Locking Bolt	Copper Zinc Alloy			DIN 1705 Or ISO 426
Disk	Ductil Cast Iron	0.705	GGG 50	DIN 1693
Disk Hingle Pin	Stainless Steel	1.4021	X20 Cr13	DIN 17440
Spring Pin				DIN 1481
Body Seat Ring	Copper Zinc Alloy			DIN 1705 Or ISO 426
Seat Washer			NBR	DIN 53538 Or ISO 4658
Cover Gasket				DIN 3754
Cover Bolt			Ck 15	DIN 933
Spring Washer	Spring Steel		Fst	DIN 267-26

MAHAB AB IRANIAN

Cast Iron Strainer

MAHAB AB - IR



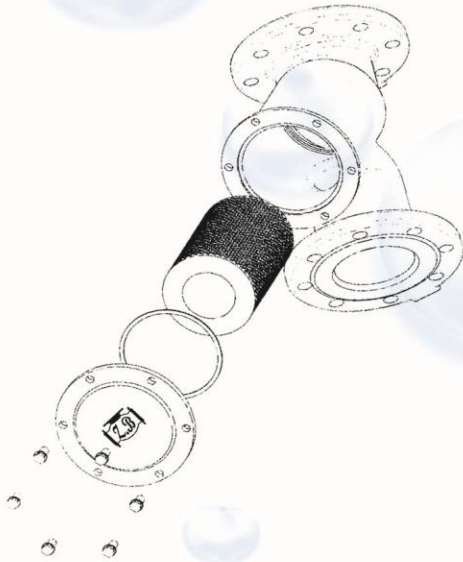
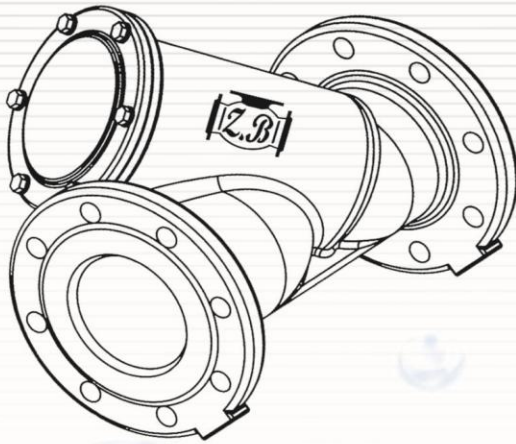

Cast Iron Strainer

Technical Specification:

10bar Nominal Pressure (PN10 & PN16)

50-250 mm Nominal Diameter(2"-10")

Gray cast iron(GG25)body material

Stainless steel(1.4301)Filter element

Body testing(according Iso5208)

Powder electro static epoxy coating

Flange mating dimation standard (DIN9501)

Space requirement standard(DIN3202)

180°C working Temperature

Suitable for water , oil and steam

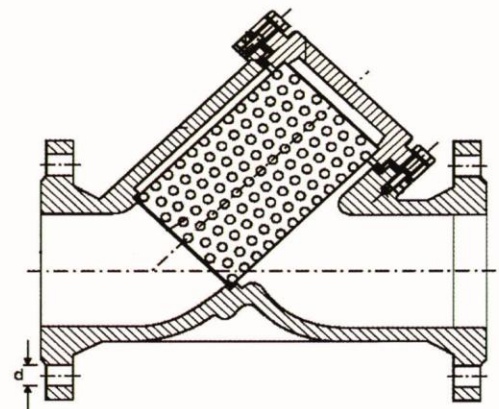

The Material of Parts, According to DIN 3352

Part Name	Material Group	Material no	Code No	Material Standard
Body	Gray Cast Iron	0.6025	GG25	DIN 1691 Or ISO 185
Filter Element	Stainless Steel			
Gaskets				DIN 3754
Cover	Gray Cast Iron	0.6025	GG25	DIN 1691 Or ISO 185
Bolt & Washer				DIN 933

* as required

MAHAB AB IRANIAN

MAHAB AB - IR

Pressure Reducer Valve

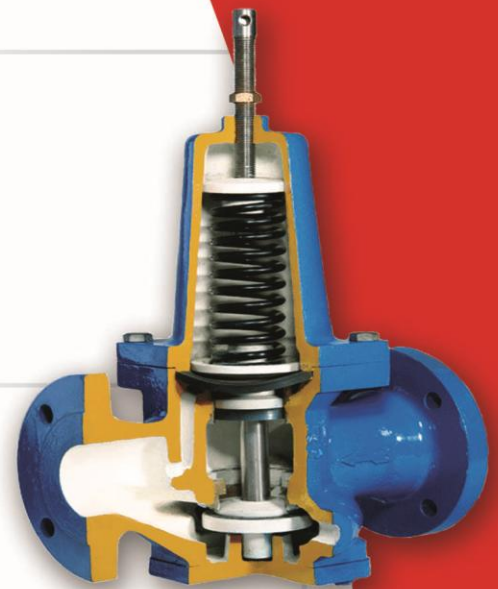

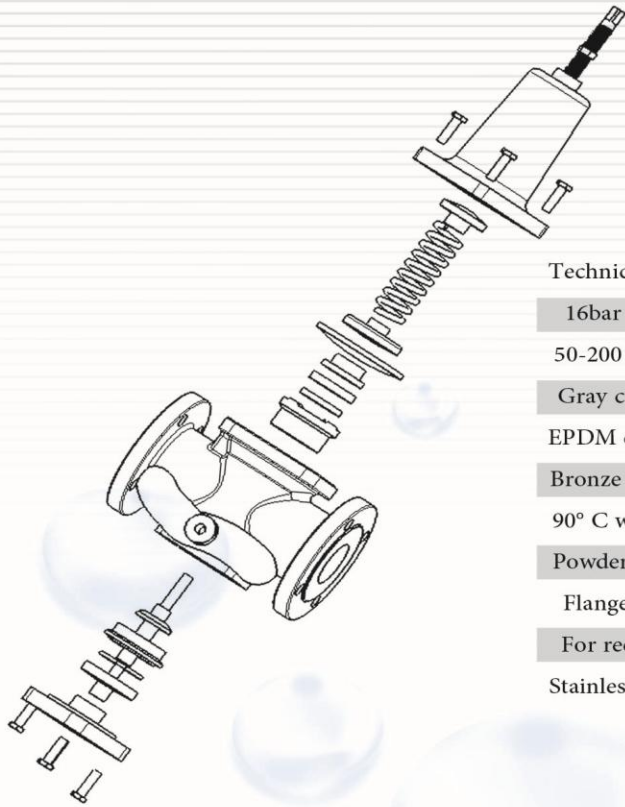

Pressure Reducer Valve

Technical Specification:

16bar Nominal Pressure(PN10&PN16)

50-200 mm Nominal Diameter(2"-8")

Gray cast iron(GG25)body&bonnet material

EPDM diafragm

Bronze seat ring

90° C working Temperature

Powder electro static epoxy coating

Flange mating dimention standard (DIN9501)

For reducing the water flow Pressure

Stainless Steel(X20Cr13)shaft material

The Material of Parts, According to DIN 3352

Part name	Material
body	GG25
ring	Copper zink alloy
cylander	Copper zink alloy
gate	GG25
piston	GG25
rubber's gate holder	GG25
rubber's piston holder	GG25
Diaphragm holder	GG25
spiral holder	GG25
spiral	Steel(1.4310)
bonnet	GG25
cover	GG25
main shaft	Stainless steel(420)
set shaft	Stainless steel(420)
rubber's gate	EPDM
rubber's piston	EPDM
Diaphragm	EPDM

MAHAB AB IRANIAN

MAHAB AB - IR

Safety valve



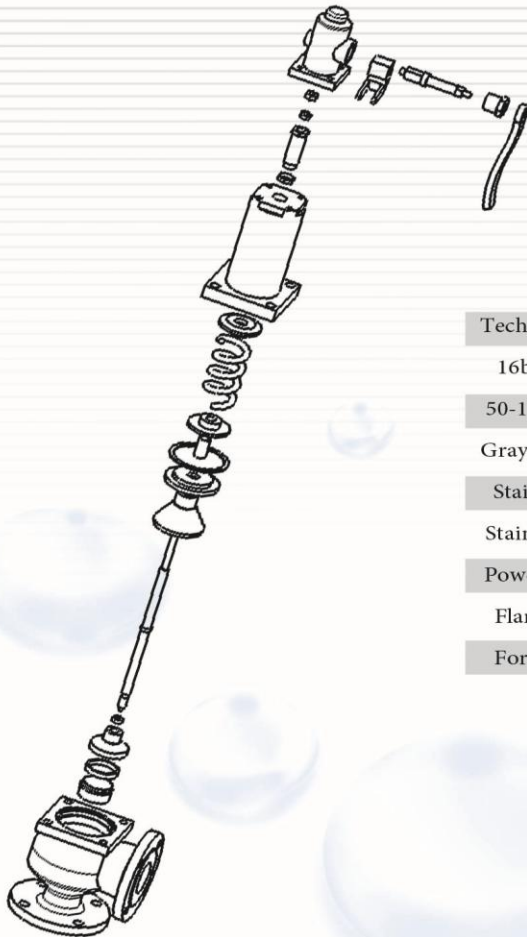

Safety valve

Technical Specification:

16bar Nominal Pressure(PN16)

50-100 mm Nominal Diameter(2"-4")

Gray cast iron(GG25)body material

Stainless steel(1.4301)sealing ring and disk material

Stainless Steel(x20Cr13)shaft material

Powder electro static epoxy coating

Flange mating dimation standard (DIN9501)

For water , steam , oil and air

The Material of Parts, According to DIN 3352

Part name	Material
body	GG25
bonnet	GG25
gate	stainless steel(304)
spiral holder	GG25
Guide	GG25
gate guard	GG25
head bonnet	GG25
Plug	copper zink alloy
handle	GGG40
spiral	steel(1.4310)
set nut	copper zink alloy
set shaft	stainless steel(420)

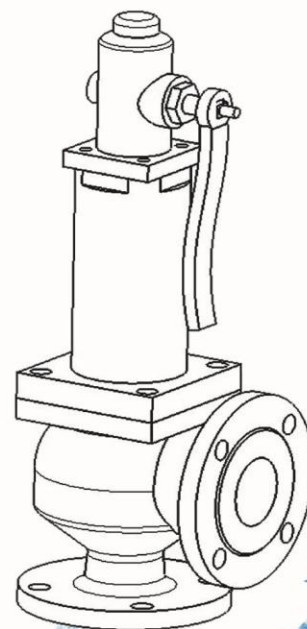

MAHAB AB IRANIAN

MAHAB AB - IR

Hidro Mechanic Float valve





Hidro Mechanic Float valve

Technical Specification:

16bar Nominal Pressure(PN16)

50-200 mm Nominal Diameter(2"-8")

Gray cast iron(GG25)body material

Stainless Steel(X20Cr13)shaft material

Cast bronze(ASTM-84400)sealing ring material

Powder electro static epoxy coating

Flange mating dimation standard (DIN9501)

The Material of Parts, According to DIN 3352

Part name	Material
body	GG25
cover	GG25
cylander	copper zink alloy
Guide	copper zink alloy
piston	GG25
Plug	GGG40
handle	GGG40
piston`s cover	EPDM
main shaft	ST37
strap	ST37
ball	ST37
rubber`s piston holder	ST37

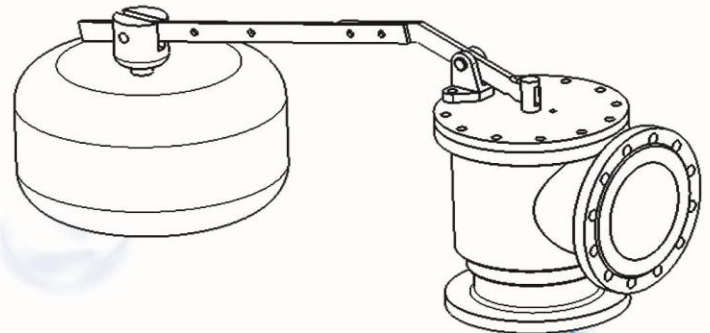

MAHAB AB IRANIAN

MAHAB AB - IR

Knife Gate valve

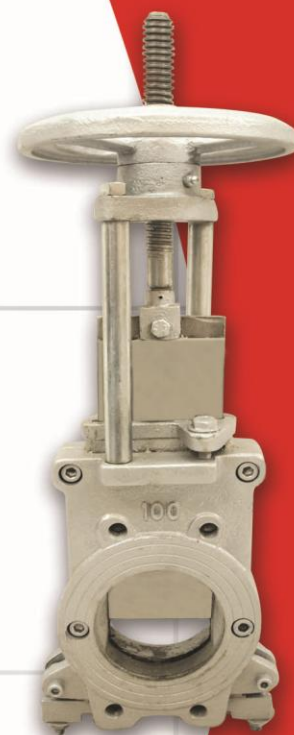
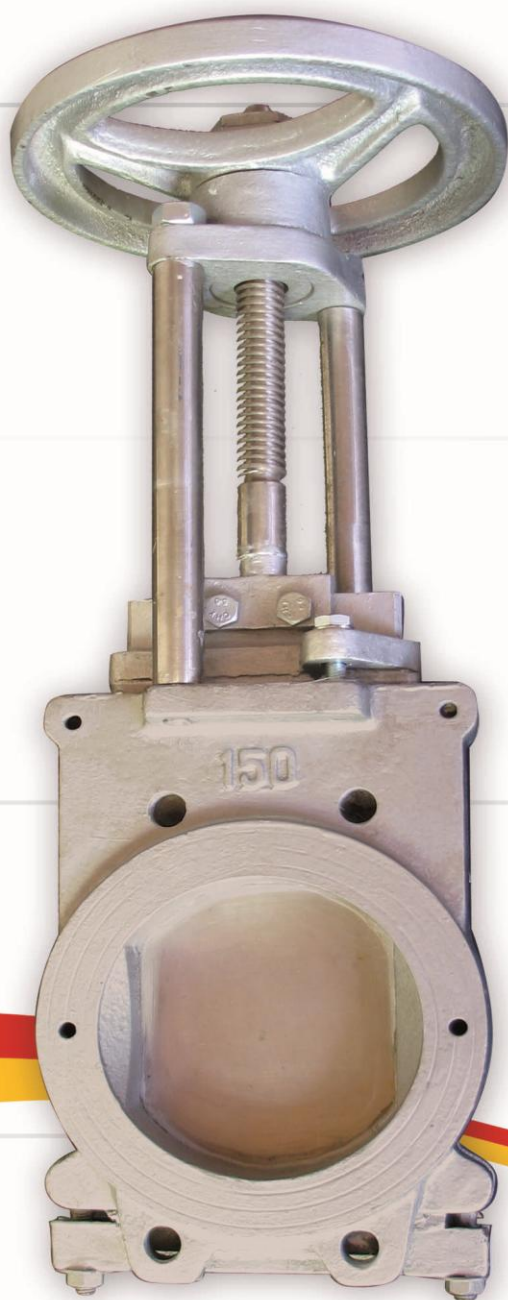

Knife Gate valve

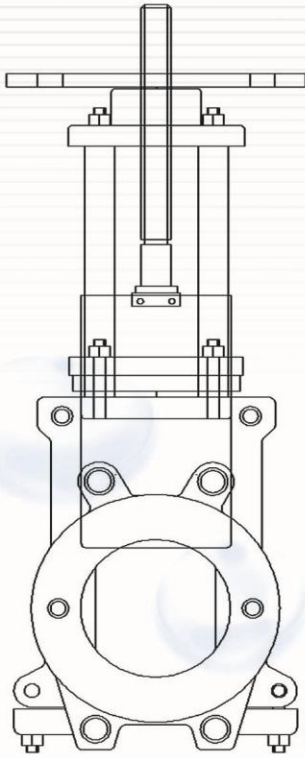

Technical Specification:

10bar Nominal Pressure(PN10)

50-200 mm Nominal Diameter(2"-12")

Ductile iron (GGG40)body

Stainless steel(1.4301)blade material

Stainless Steel(x20Cr13) main shaft material

For viscous fluid

250° C working Temperature

The Material of Parts, According to DIN 3352

Part name	Material
Body	GGG 40
Under cover	GGG 40
Upper cover	GGG 40
Gland	GGG 40
Blade	1.4301
Stem	1.4021
Stem Nut	Brass
Handweel	GG 25
Bracket shaft	CK 45
Key	1.4571
Bolts	A2
Packing	Tallowed cotton

MAHAB AB IRANAIN

Air valve

MAHAB AB-IR



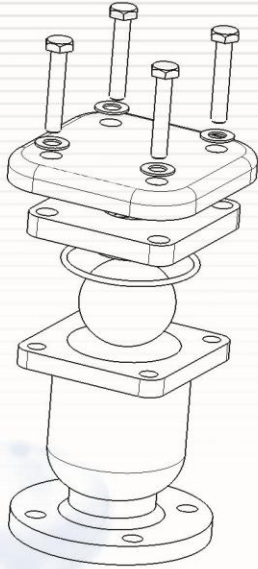

Air Valve

Technical Specification:

10bar&16bar Nominal Pressure(PN10 & PN16)

50-150 mm Nominal Diameter(2"-6")

Gray cast iron(GG25)body material for PN10

Ductile iron (GGG40)body for PN16

Sealing washer is EPDM (As required NBR)

Powder electro static epoxy coating

Flange mating dimension standard (DIN9501)

Single &double air duct with double orifice and single orifice for each models

Copper alloys inside part material

The Material of Parts, According to DIN 3352

Part Name	Material Group	Material no
body	Gray Cast Iron	GG 25
cover	Gray Cast Iron	GG 25
head cover	Gray Cast Iron	GG 25
ball	PE	
orifice	Copper Zinc Alloy	

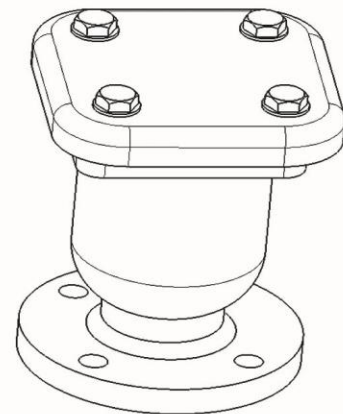

MAHAB AB IRANIAN

Flap valve

MAHAB AB - IR



Flap Valve

Technical Specification:

16bar Nominal Pressure(PN16)

80-400 mm Nominal Diameter (3"-16")

NBR or EPDM sealing washer material

Flange dimation&mating according to standard DIN EN 1092

Powder electro static epoxy coating

Stainless Steel(X20Cr13) hing pine material

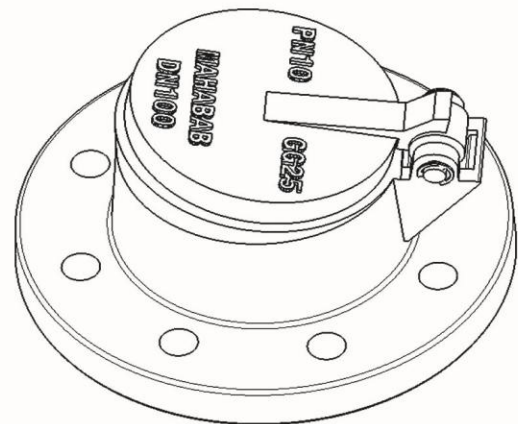
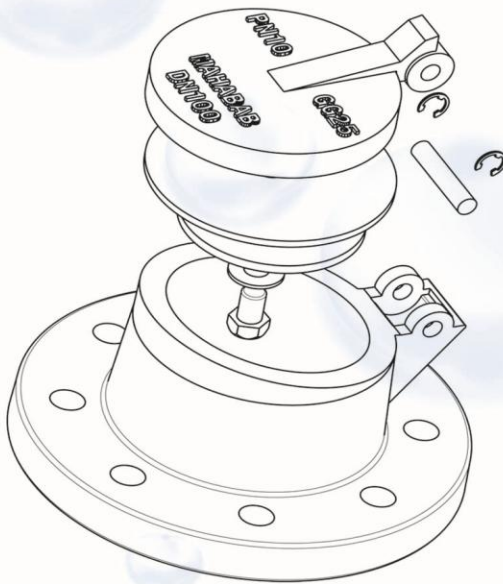

The Material of Parts, According to DIN 3352

Part Name	Material Group	Material no
body	Gray Cast Iron	GG 25
cover	Gray Cast Iron	GG 25
seal washer	rubber	NBR
pin	Stainless Steel	X20 Cr13

MAHAB AB IRANIAN

MAHAB AB - IR

Under Ground Fire Hydrant



«بسمه تعالی»

کارآفرینی یک نوع عبادت و ارزش آفرینی است.
«ماتم علم بهرگاه نفع دهنده»

برادر گرامی جناب آقای فتح الله بیگی بندرآبادی
مدیر عامل محترم شرکت مهاب آب ایرانین

کارآفرینی توأم با اندیشه های خلاق و نوآورانه در عرصه های اجتماعی، اقتصادی، فرهنگی و فن آوری
نوعی است که با اتکال به خداوند متعال و تلاش پر شور کارآفرینان و معاصر عرصه های کار و تولید این مرز و بوم به
دست می آید. اکنون که بتعالی بر اساس رای کیه علی به عنوان کارآفرین برتر بخش صنعت در هفتمین
جشنواره استان از کارآفرینان برتر (سال تولید ملی) جایست از کار و سرمایه ایرانی انتخاب شده اید،
هست و تلاشگران راج نماده برای شما در همه عرصه های خدمت و مجاهدت در پناه الطاف ایزد متعال سعادت
و تعالی مسکت بینمایم.

سید جواد منصوری

مدیرکل تعاون، کار و رفاه اجتماعی استان قم



جمهوری اسلامی ایران
وزارت تعاون، کار و رفاه اجتماعی

اداره کل تعاون، کار و رفاه اجتماعی استان قم
تولید ملی، جرابست از کار و سرمایه ایرانی

۱۳۹۱ ماه ۵



Rubber seat gate valve



Metalic seat gate valve



Cast iron strainer



Swing type check valve



Disk discharge valve



Gearbox butterfly valve



Handle butterfly valve



Pressure reduce valve



Butterfly valve



Safety valve



Hidro mechanic float valve



Knife gate valve



Air valve



Flap valve



Under ground fire hydrant